



Institute of Technology in Architecture  
Faculty of Architecture / ETH Zurich

# **ZE\_Container**

**Zero Emission Container - Integrated Design Research Studio (DRS)**

**Prof. Arno Schlüter**

**Architecture & Sustainable Building Technologies (SuAT)**

**Institute of Technology in Architecture (ITA)**

**Department of Architecture / ETH Zürich**

**SuAT**

**ETH**

Eidgenössische Technische Hochschule Zürich  
Swiss Federal Institute of Technology Zurich

# Assistant Chair of Architecture & Sustainable Building Technologies

- Integrated design for LowEx Zero Emission architecture
  - Building , systems and energy modeling
  - Performance assessment and simulation
  - Information management and analysis
- Operational Strategies
  - adaptive and intelligent behaviour
  - efficiency and user well-being

# Zero Emission Container - Concept

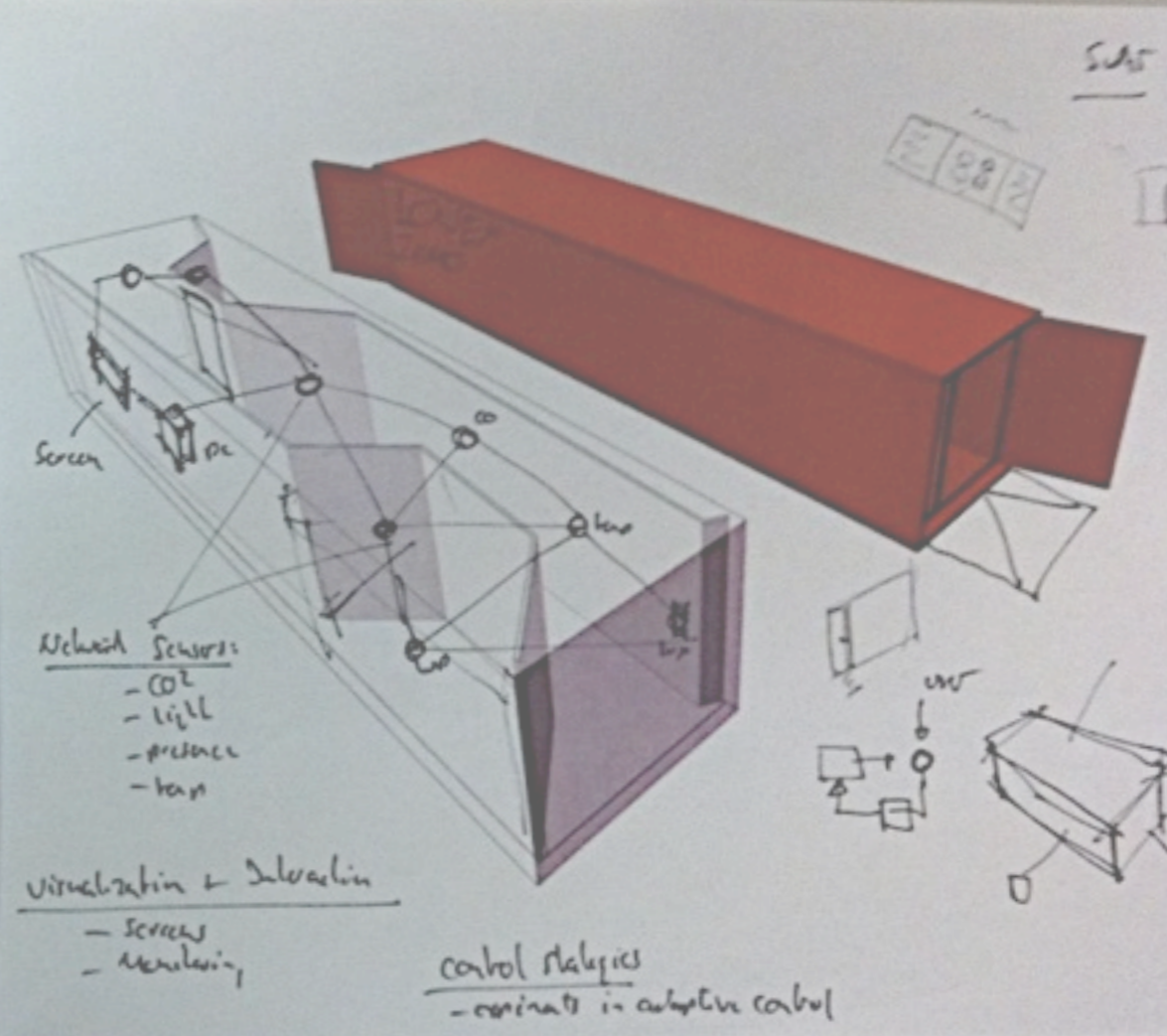
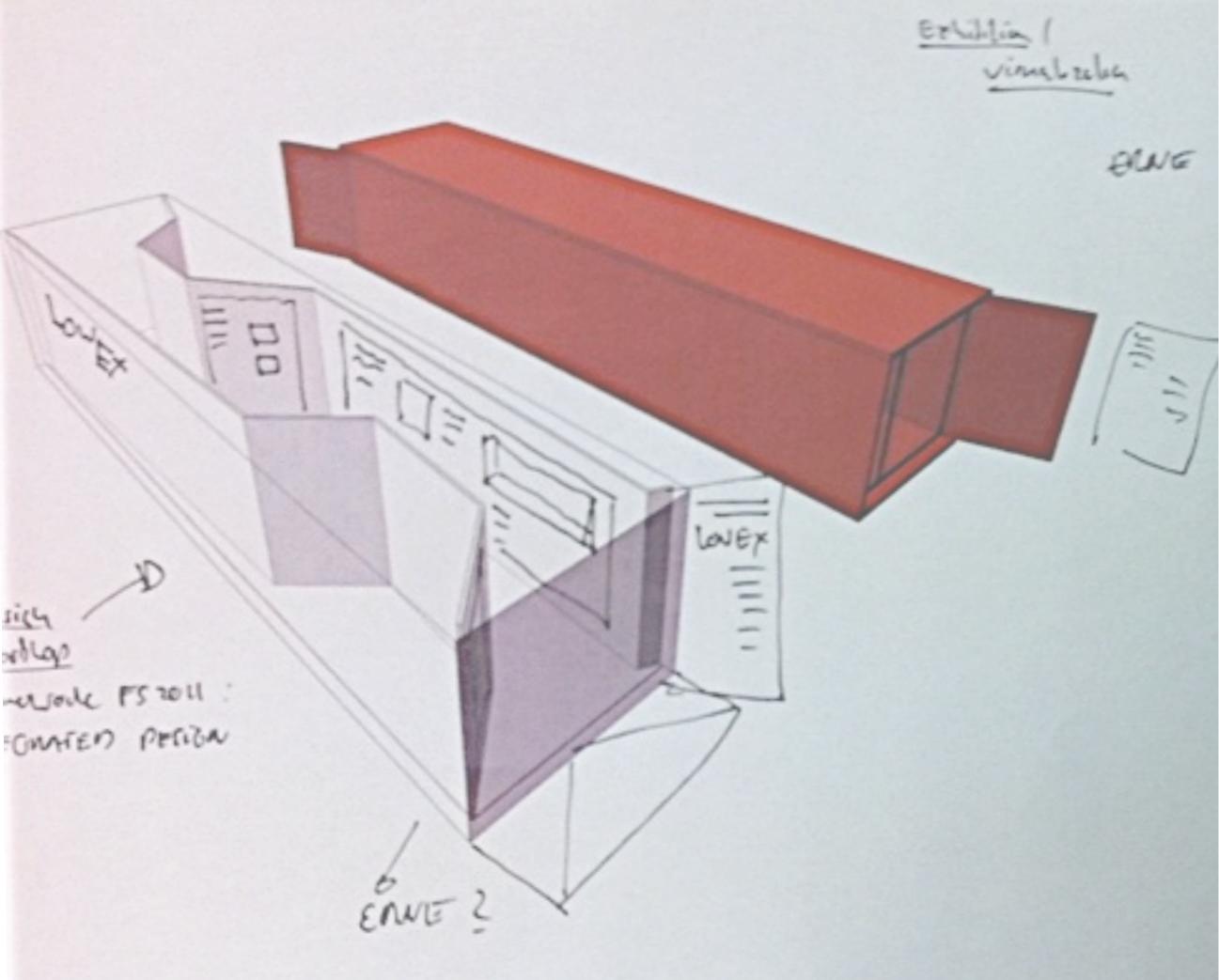

# Zero Emission Container - Concept

- Mobile research lab for Zero Emission LowEx technologies
- Functional showroom and exhibition on site
- Research object



# Research Objectives

- Transformation of LowEx concepts and technologies to the Singapore conditions
- Integration of technologies towards a Zero Emission architecture
- Adaptive operational strategies using sensing, intelligent control and feedback



# Requirements

- Mobility / transportability
- High-level interior design with integration of LowEx technologies
- High-level exterior design with functional capacities
- Integration of sensors and control strategies



# LowEx Technologies

- HVAC
  - LowEx heat pump / chiller
  - Decentralized ventilation / dehumidification
  - Multifunctional ceiling panel
- Lighting / Daylight
  - M-Glas
  - LED Lighting
- Photovoltaic / Photovoltaic-thermal modules
- Digitalstrom
- ...

# Integrated Design

- Use of Building Information Modeling from the scratch
- Storing of multidisciplinary information over the entire building process
- fast real-time performance assessment
- Integration of systems

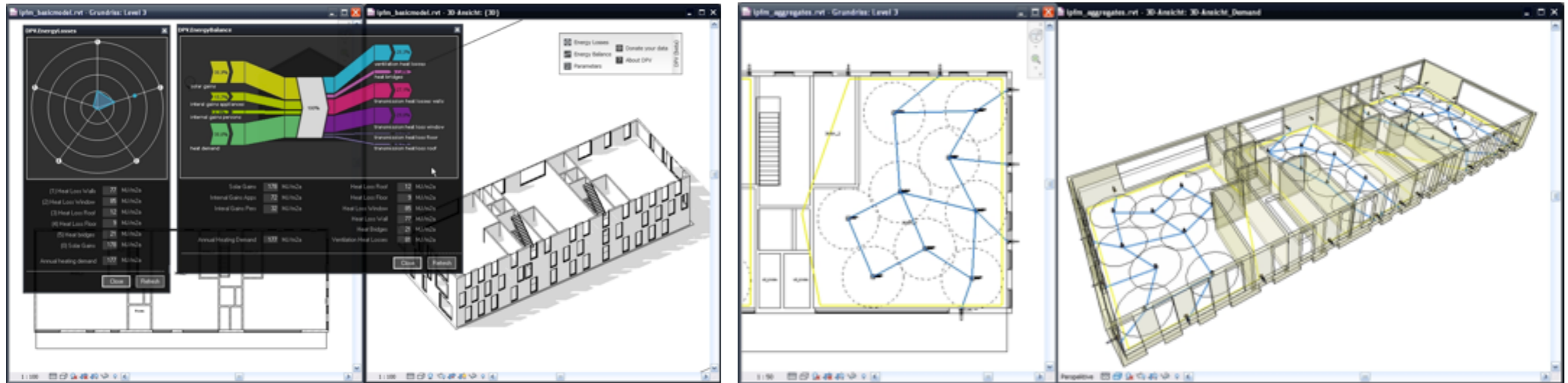

## Design Performance Viewer (DPV): Building Energy Performance in Early Design Stages

06.2010  
ETH Zurich / KEOTO AG

**ETH**

Eidgenössische Technische Hochschule Zürich  
Swiss Federal Institute of Technology Zurich

KEOTO



# Sensing and Monitoring

- Distributed Sensing: Air quality, lighting, temperature, presence, humidity
- Distributed data storage
- Data mining and analysis

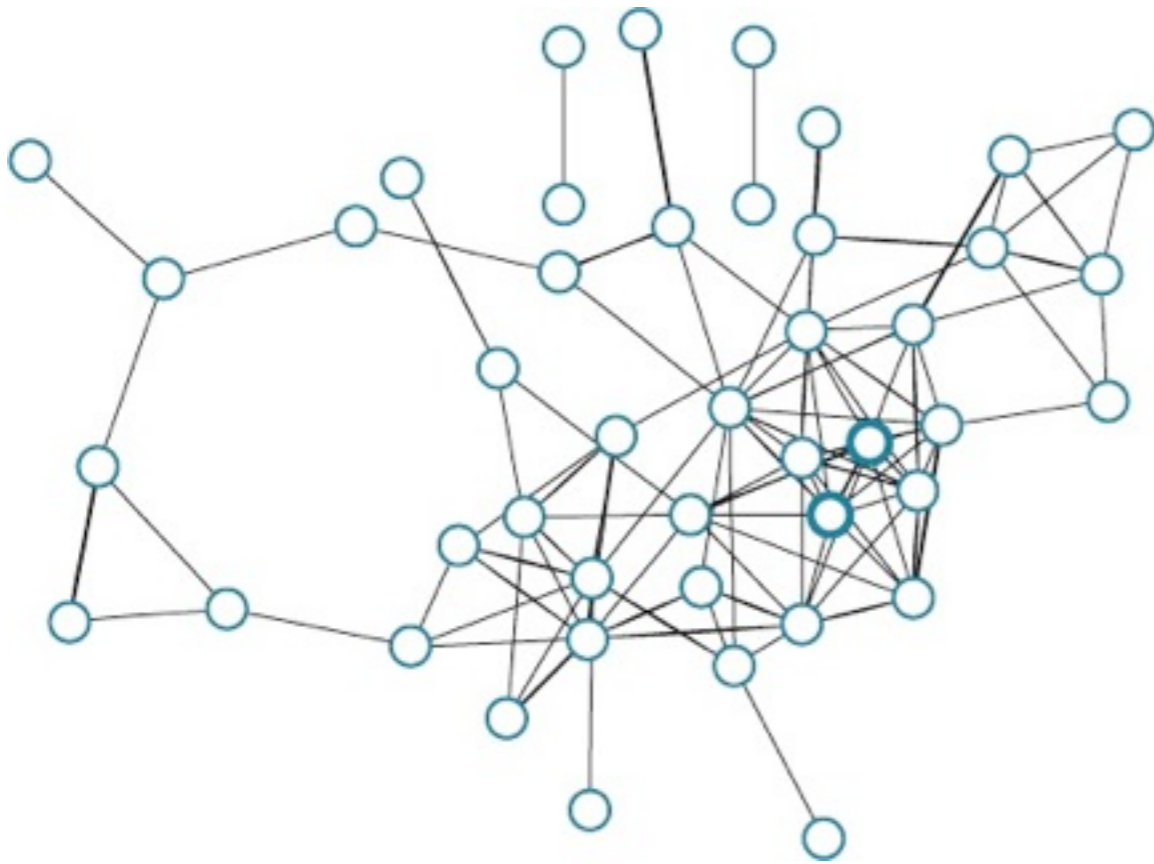

# Adaptive Operational Strategies

- Derivation of adaptive operational strategies for systems
- Maximizing available renewable energy sources and efficiency of systems
- Centered around user goals
- Feedback using advanced visualization techniques

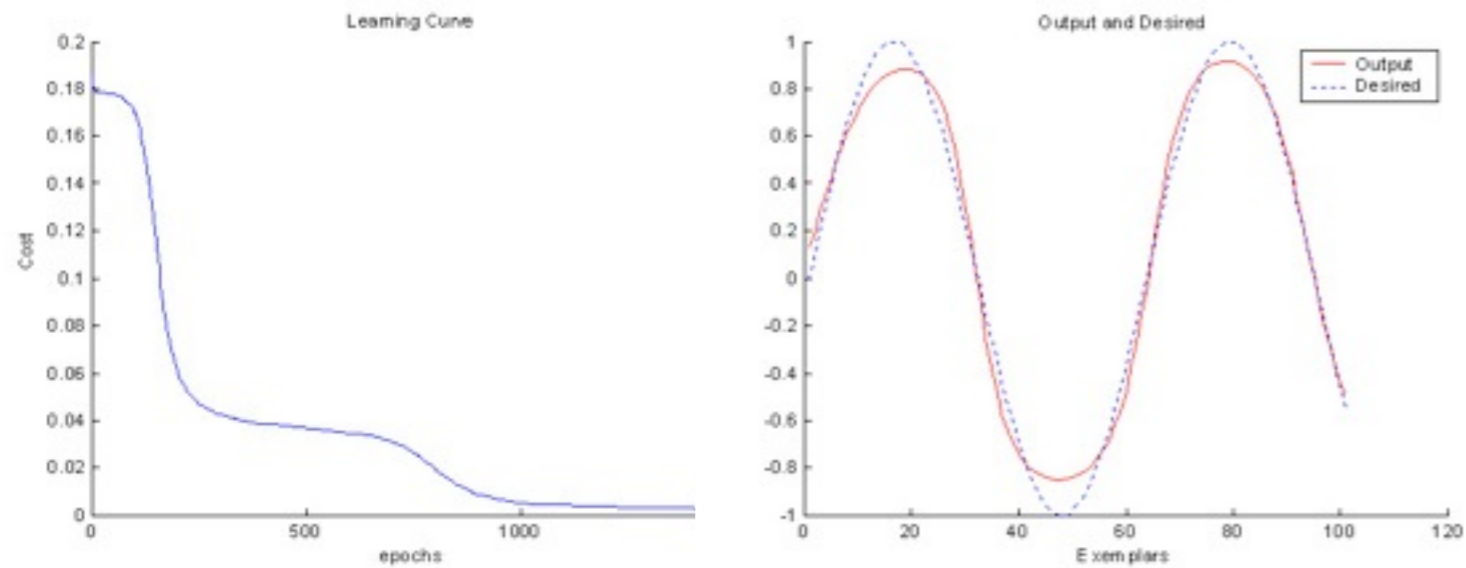

Quelle:

# Design Research Workshop / January 24-January 31

- Student group work, tutored
- Workshop objectives
  - Concept development according to the requirements
  - Interior design integrating technologies
  - Functional exterior design, high visibility

# Basics and Interior Design

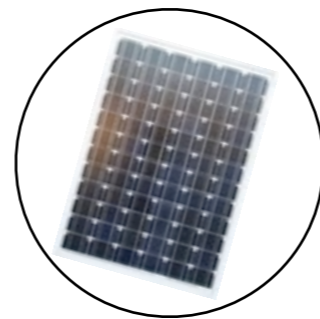
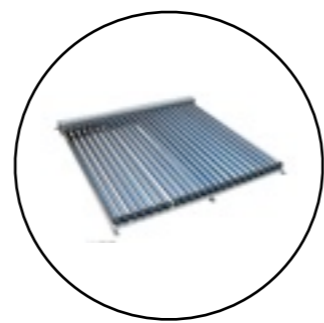
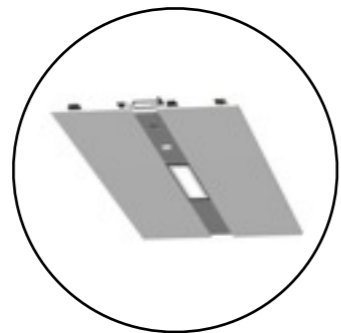
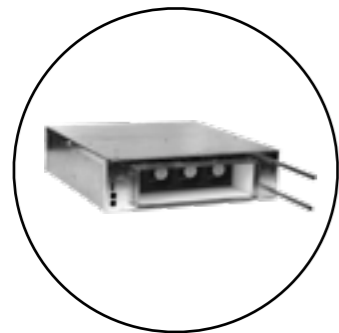
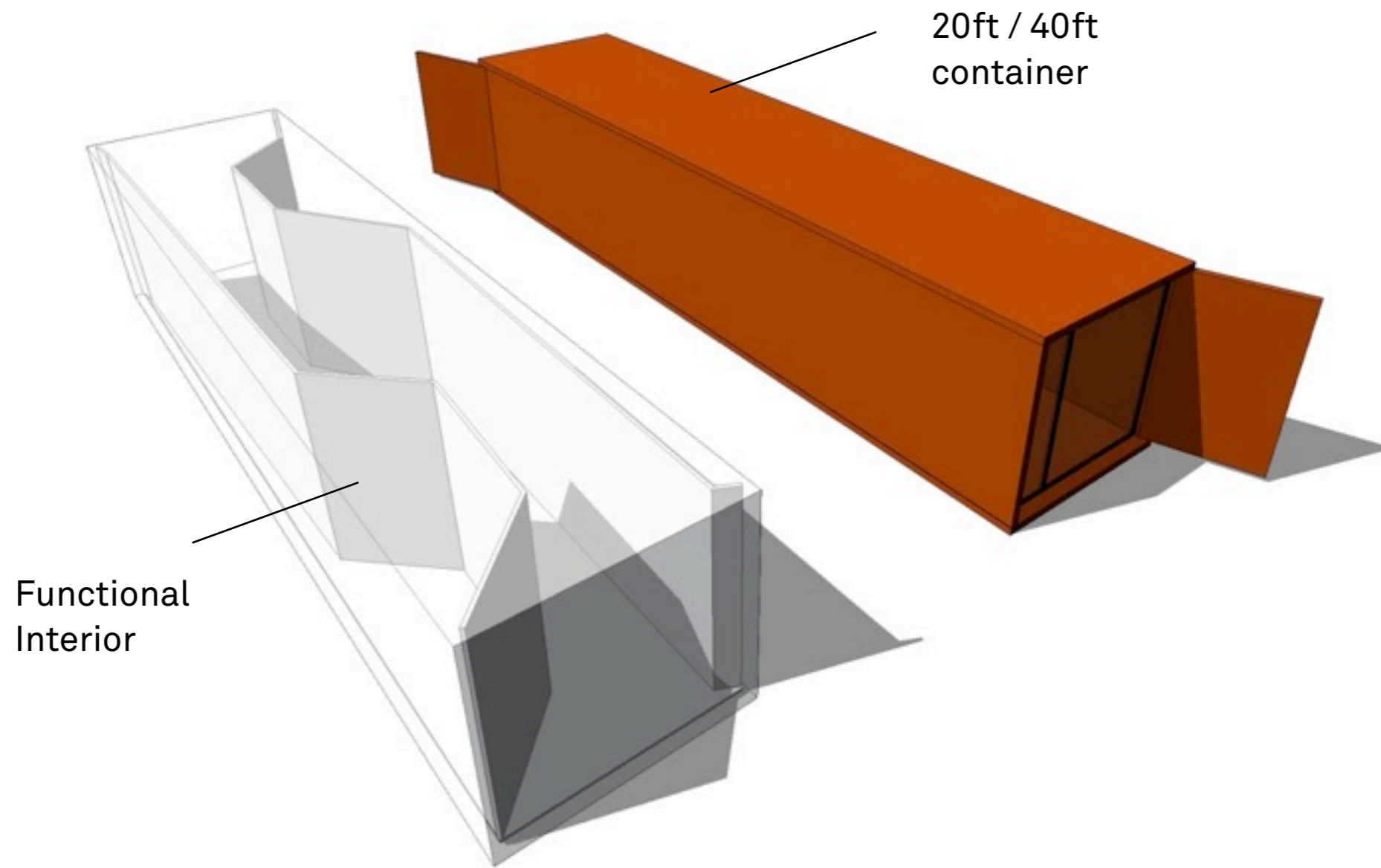

# Exterior Design

