



Institute of Technology in Architecture
Faculty of Architecture / ETH Zurich

Decentralized (heat) pumping

Enabling more intelligent and effective system operation

Matthias Mast
Professur für Gebäudetechnik
26. November 2010

ETH

Eidgenössische Technische Hochschule Zürich
Swiss Federal Institute of Technology Zurich

Conventional heating system

Schematic view

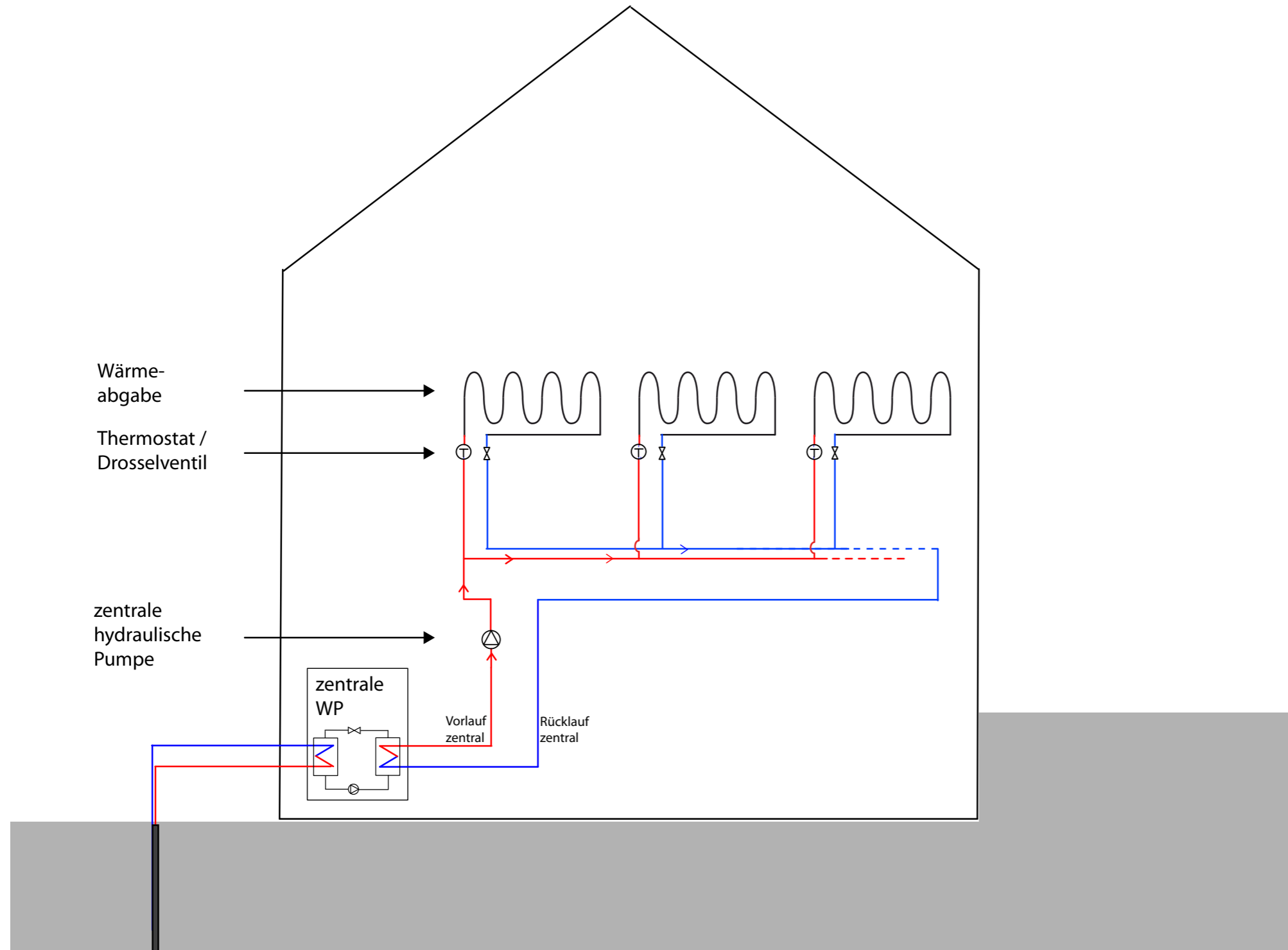

New system layout

Benefits

- system can react faster and has more degrees of freedom, leading to new control strategies
- supply temperature and thereby temperature lift of main heat pump could be reduced
- no need for 3-pipe systems (important for renovation projects)

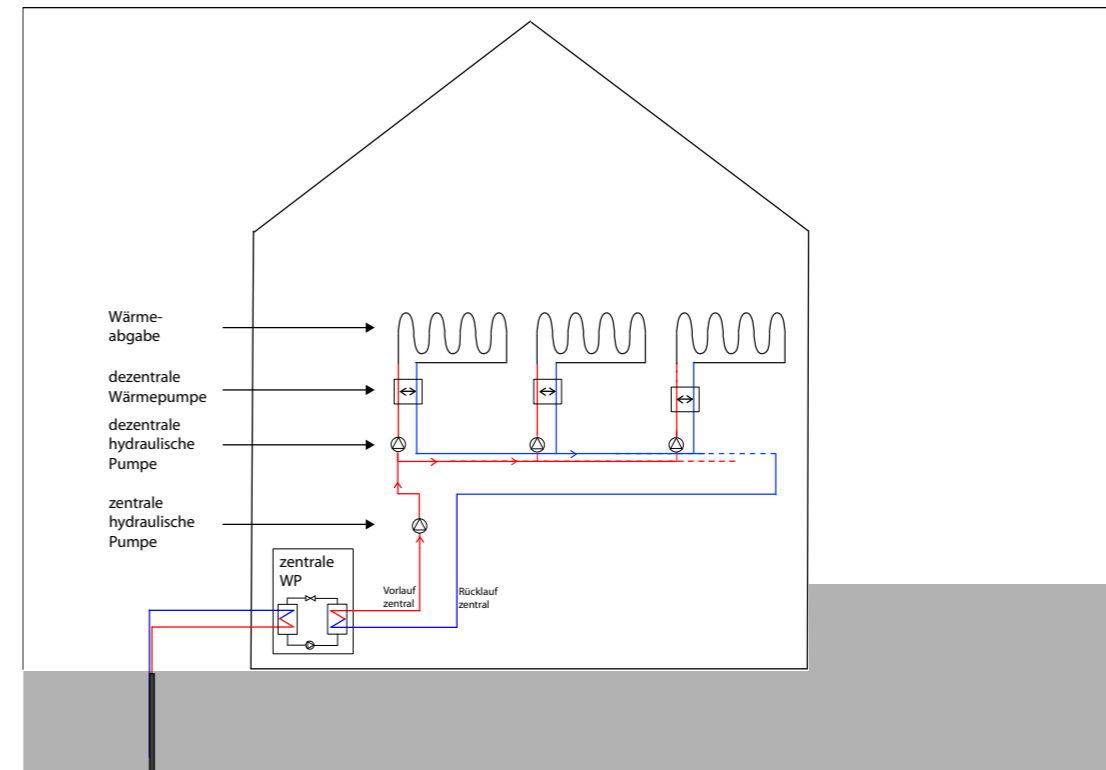

Local hydraulic pumping

Research and Hardware

- simulation and measurements by TU Dresden
- led to commercial system by WILO SE (Germany)
- system consists of pumps and communication network
- at HPZ and B35:
 - simple DC-pumps without special communication network
 - controlled via digitalstrom



Zahlen Richter ?!



Local hydraulic pumping

Example from WILO SE



Local heat pumping

Hardware

- At the moment no such system on building level exists
- as part of the research:
 - construction of a prototype, using thermoelectric modules
 - development of model to simulate system

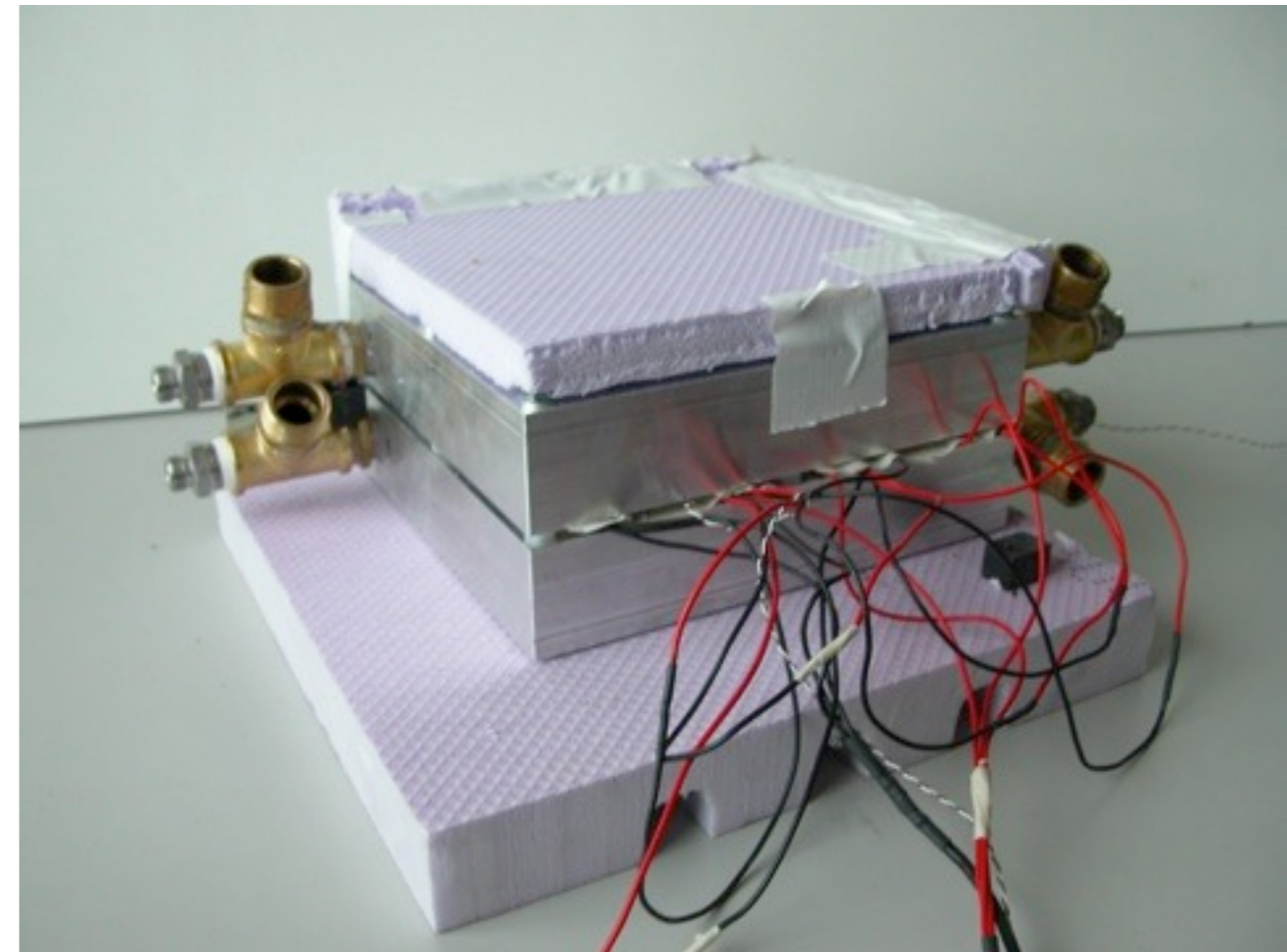



Institute of Technology in Architecture
Faculty of Architecture / ETH Zurich

Turbocompressor heat pumps

Research collaboration with HS Luzern and Celeroton

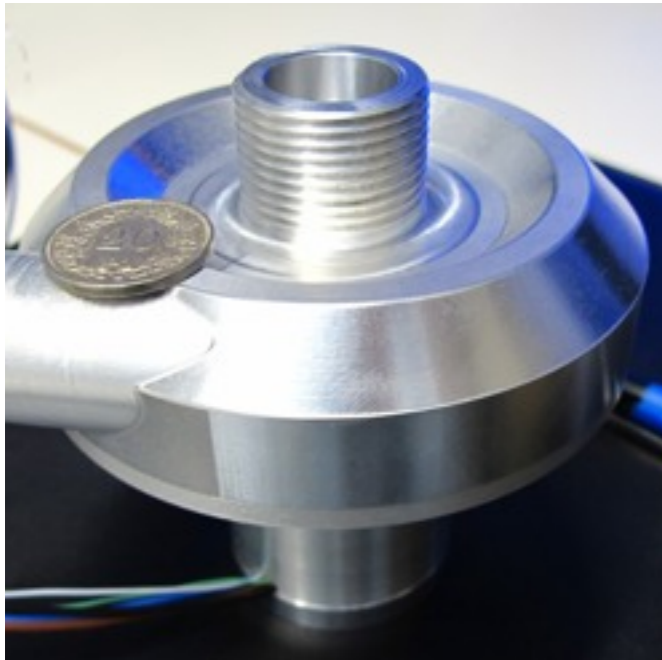

ETH

Eidgenössische Technische Hochschule Zürich
Swiss Federal Institute of Technology Zurich

Turbo compressors for heat pump

General overview

- Turbo compressors used in units with high power
- Could be efficient compressors for small temperature lifts or miniature heat pumps

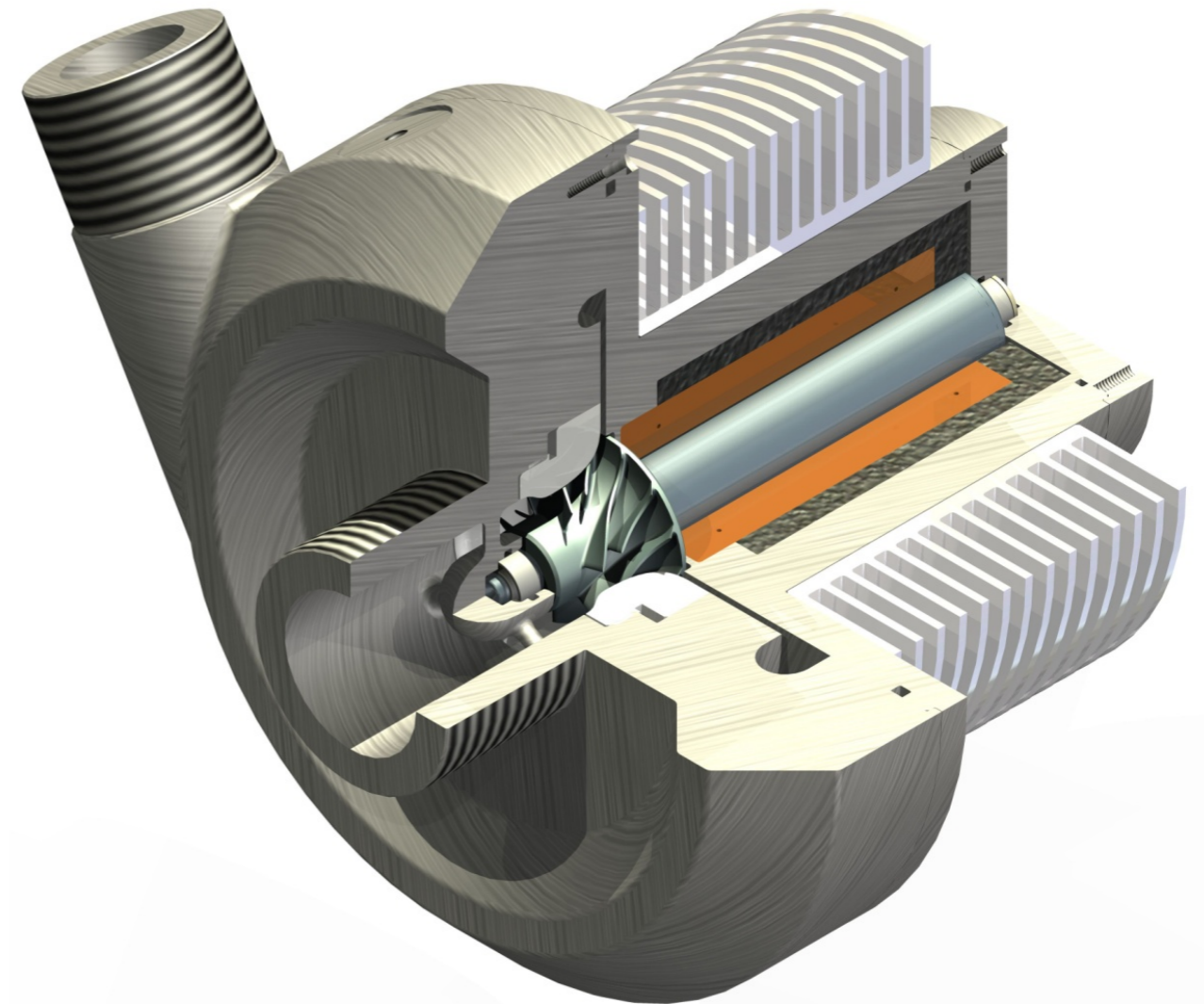

Turbocompressor heat pump

research collaboration with HS Luzern and celeroton

- **Prototype of electric turbocompressor heat pump:**

- **working fluid: butane**

- **Temperature lift: 28 K**

- **Heating power: 10 kW (th)**

- **oil free bearings**

- **size:**

- **length: 90 mm**

- **diameter: 40 mm / 90 mm**

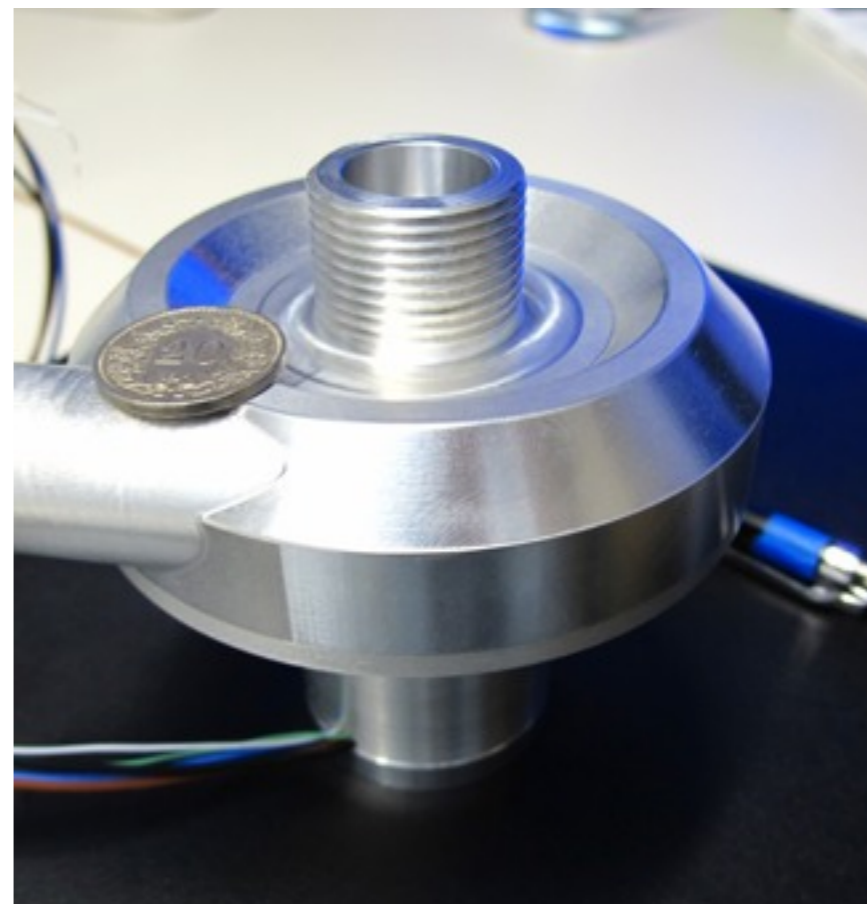
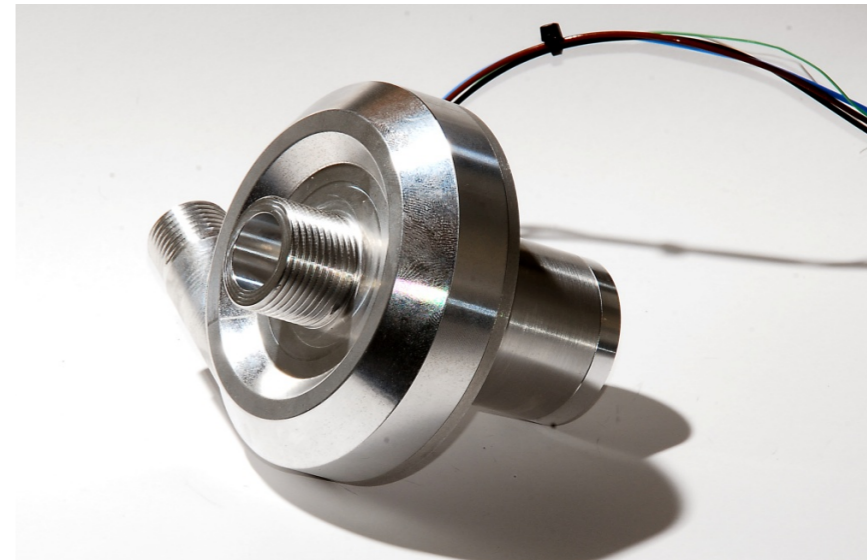

Outlook

Next steps

- Prototyp of compressor has been built
- Measurements in 2011 determining COP and compressor performance map
- miniaturization of electronics

